

# *White's Electronics, Inc.*

1011 PLEASANT VALLEY ROAD

SWEET HOME, OREGON 97386

## OPERATORS INSTRUCTIONS



*Manufacturers of The World's Largest Line of Mineral and Metal Detectors*

MINERAL AND METAL  
DETECTORS

ELECTRONIC  
MAGNETOMETERS

SUPER GEIGER AND  
SCINTILLATION COUNTERS

ULTRA VIOLET  
LIGHTS

OPERATING INSTRUCTIONS  
for  
COINMASTER MODEL 2TR HIP MOUNT

(10 Turn Control)

Please follow these instructions carefully, to operate the instrument correctly and practice with it at every opportunity.

INTRODUCTION

We do not believe that you can buy a finer instrument than you have chosen for the use that the instrument is designed for, but remember that the instrument is no better than its operator, (even though we have heard customers say that the instrument was smarter than they.) You are the operator, and the more familiar you become, through use and practice the better operator you will be. The better the operator, the more finds you will make.

GENERAL DESCRIPTION

These instruments are completely transistorized (solid state), giving maximum sensitivity, excellent reliability, and economy in operation. They are designed specifically for coin hunting, but have features which allow them to be used for general exploration, and even prospecting on a limited basis.

The audio system is complete, offering both earphone and speaker operation, controlled by a common volume control.

These instruments have a sensitive meter giving good reactions on finds, as well as testing both battery systems under operating conditions.

These instruments employ the balanced induction principle of operating, the loop being the heart of the system.

Batteries used are penlight, size "AA" 1 1/2 volt cells. Fourteen are required for operation, six cells in one holder, yielding 9 volts, and eight in the other holder for 12 volts.

ASSEMBLY

1. Fit the two sections of the loop rod together.

NOTE: This is an adjustable rod. To adjust for length, adjust the smaller section of the rod to the desired length, align the loop and then tighten the knurled adjusting ring, finger tight.

2. To install the loop it will be necessary to remove the 8/32 X 1 1/2" round head bolt from the loop. Place the 8/32 X 1 1/2" round head bolt through the loop clevis bracket and plastic rod extension.

Install the thumb nut on the threaded end of the loop bolt.

CAUTION: Do not over-tighten. Use only enough pressure to make a snug fit. The thumb nut has been designed for hand-tightening. Tools should not be necessary.

3. Now that the loop is attached to the end of the rod, insert the loop plug into the matching socket on the front panel of the instrument.

CAUTION: Do not force the loop socket and plug together. The socket and plug are keyed to allow mating with only the correct pin alignment.

#### BATTERY INSTALLATION

Now open the battery compartment by releasing the latches on each side and swinging the door open from the top. Free the battery connectors by removing the tape. Note one white connector and one black. Also, a white battery holder (8 cells), and a black holder (6 cells). The white is 12 volts D. C., and the black is 8 volt D. C.

Be sure to match white to white, and black to black. Snap the battery connector onto the battery holder, noting the connector and battery holder are set up to match in only one polarity. Be sure to observe this polarity because damage can be done to the electronics if forced together in error. (See Battery Diagram)

#### FUNCTION SWITCH AND BATTERY TESTING

With the Function Switch in the OFF position, the batteries are disconnected from the circuitry.

With the Function Switch in the 9 or 12 position, the batteries are connected to the circuitry and the meter is connected to check the batteries. In the 9 position you may check the 9 volt pack (6 cells) and in the 12 position you may check the 12 volt pack (8 cells). Good batteries read 40 to 50 on the meter. When your reading drops to 40 on the meter, it is time to replace that set of batteries. For best performance the readings should not drop below 40 even when the instrument is sounding loudly. It is a good idea to carry an extra set of batteries with you for replacement when necessary.

When the Function Switch is in the ON position, the batteries are connected to make the circuit operate and the meter is connected to read intensity.

#### METAL AND MINERAL SETTINGS

The tuner adjusts the level of sensitivity as well as selecting Metal or Mineral.

The tuner is a ten-turn control; actually the knob will turn around indefinitely, but you can tell when you have reached the end of the tuning range because at that point there is a sharp increase in the force required to turn the knob.

Approximately in the center (5 turns from either limit) of the tuning control is a quiet spot called the Null. On either side of the null the instrument sounds off loudly. At either edge of the null the sound starts softly and becomes louder as you turn away from the null. The point where the sound first comes on softly is known as the threshold level. The threshold level is the best setting for maximum effective sensitivity. When you are tuned to the null, you must turn counter-clockwise to reach the metal threshold level. You must turn clockwise to reach the mineral threshold level. The width of the null is at least two full rotations of the tuner control knob.

For effective results, the adjustments must be made with the instrument in the hunting position, (see Figure B, under operating instructions), holding the loop as close to the surface of the area to be explored as is practical for movement of the loop.

#### INTENSITY METER ZERO

It is normal for our intensity meters to read below zero when the instrument is in a state of "NULL". This is due to reverse bias applied to the meter to give a faster response time.

Meter readings are a relative indication of the strength of the find. A strong signal could be a large object or an object very close to the surface. The meter can also be used to indicate the concentration or strength of minerals.

The meter readings are not calibrated to give a direct indication of depth but with practice and experience, it will tell you much about the size, depth and content of the object you have detected.

#### HUNTING METHODS AND TECHNIQUES

For Metal Detection set the instrument on the METAL side of null, adjust the volume to the desired level and meter to the correct reading.

When passing the loop over a non-magnetic conductive metal, such as the metal sample you received with your instrument, the sound will increase in the speaker and a higher reading will be retained as long as the loop is held over the metal object. As soon as the loop passes away from the metal object, the sound will lower in volume, and the meter will lower in reading, and return to approximately the same reading as before the object was detected. No reading will be noticed when passing the loop over the mineral sample.

Earphone Usage: To use the earphone install its plug into the jack on the instrument. Note this cuts off the speaker giving privacy in listening. You may use the earphone whenever you wish, its special feature being that of giving you a concentrated tone close to your ear, which excludes interfering noises about you.

Tin cans, bottle caps, tin foil, aluminum foil, cartridge cases, coins, silver, gold, copper, lead and brass are some of the highly conductive metals that will read on the Metal setting.

Operating Instructions  
COINMASTER 2TR HIP MOUNT

-4-

The instrument is not designed to react to sticks, rags, bones, paper, non-magnetized rocks, nor other non-magnetic objects or non-mineralized objects.

To locate hidden or buried metal objects, slowly and systematically sweep the loop across the area to be checked, being very careful to hold the instrument so that the loop is held at as constant and uniform height as possible with the least up and down variation in relation to the formation or ground you are using the instrument over. When searching for small objects, such as a single coin, the instrument should be tuned in with the loop held as close to the ground as possible. Hold this height as close as you possibly can, and search the ground carefully, usually on the surface, if possible, depending on the surface you are using the instrument over. If the ground is rough, you may have to zero the instrument in higher. For larger objects, one can hold the instrument approximately 1 to 2 inches above the surface to be explored. With each sweep of the instrument you will cover approximately 6 feet by 3 inches. Keep repeating this process until you have explored the entire area. If there is anything under the surface, and it is within detectable range of the instrument, you should be able to find it.

In the short green grass, such as a lawn, it is possible to place the loop on the grass, tune it in, and slide the loop over the grass to locate the smaller objects. The loop automatically is kept at the same height by the grass, so a uniform and more constant meter reading may be maintained, which is important for the very small objects. For large objects, the instrument may be carried at a higher elevation, and it is not so critical to height variation, and will respond to the larger metal objects. To practice, lay some metal objects on a wood floor or on your lawn and move the loop over them, and notice the way the instrument responds.

It is a good policy to slightly adjust the Metal-0-Mineral every 5 to 10 minutes to keep the instrument at its highest peak of sensitivity, when searching for very small objects, such as single coins, along beaches, etc., and every 10 to 15 minutes or so for larger objects. This adjustment may need to be made more frequently, if there is a change in the mineralization of the ground you are searching.

The volume is increased by turning the Volume Control to the Right, and is decreased by turning it to the Left. The Volume Control does not increase or decrease the sensitivity of the instrument.

The instrument may be used around water, but do not submerge the loop in water, (unless a waterproof loop has been ordered with the instrument.)

For Mineral prospecting, set the instrument on the Mineral Side of Null with the desired volume and meter reading.

You may now locate and trace detectable mineralized veins that have all magnetic content with this fine instrument. The instrument will usually read the highest and sound the loudest over the highest mineralized spots in the veins.

It is a good idea to practice with the instrument before taking it into the field. Passing the loop over the mineral sample, you received with the instrument, will cause the meter to read higher and the sound in the speaker will also increase, and this increase in sound and meter reading will remain as long as the loop is held over the Mineral sample. The meter will not read on coins, or on soft conductive metals, (when operated correctly), when set on the Mineral setting, (but will usually read on steel bolts due to their hardness and shape.)

False Readings can occur.

When you feel you are receiving a metal and mineral reaction from the same object, one of them is a false reading.

False Readings occur when an object is too close to the detecting head (loop).

The best method for determining if your reading is false is to move the loop away from the object, then bring the loop closer very slowly. The first indication is the true one.

You may experiment with this phenomenon by taking an object opposite to what you are tuned to, move this object into the field of the loop. Note the decrease in tone. Keep moving the object closer until at approximately 1/2 inch, you will hear a loud blast. This is a false reading. Note the sudden harsh sound of the false reading.

#### SERVICE - WARRANTY - REPLACEMENT BATTERIES

This model contains two battery holders containing 14 penlight batteries. You order replacement batteries direct from our plant, if you cannot find them locally.

The new penlight battery system is better in many respects to the old type batteries:

1. Longer life
2. Readily available
3. Superior performance
4. Cheaper in replacement. (if one cell fails, you only need to replace the one cell.)

Alkaline energizers and batteries of this type may be used and give even longer life. Note: All batteries last longer if used in many short periods, rather than in a couple of long periods of use.

When through operating the instrument, turn the Mineral-Metal Control to NULL, (where no sound is heard, and be sure to turn the Function Switch OFF).

The instrument has a full two (2) year warranty on parts and labor (Except batteries) to the original purchaser.

Operating Instructions  
COINMASTER 2TR HIP MOUNT

-6-

If ever in need of service, ship the instrument by insured parcel post, freight, or stage, prepaid and enclose a letter advising the nature of your troubles. It may be returned to the factory address listed below, or to one of our Service Centers listed in the back of this booklet.

CAUTION: Care should be taken in excessively cold weather to protect the instrument as well as the batteries from freezing.

The instrument should also be protected from exposure to excessive heat when not in use.

If the instrument is to be laid away for any great length of time, the battery pack should be unsnapped and the pack removed from the instrument and the batteries stored in a dry, cool place. This will prevent damage to the instrument in case one or more of the batteries are damaged or in case the power switch is left on or gets turned on accidentally.

WHITE'S ELECTRONICS, INC.  
1011 Pleasant Valley Road  
Sweet Home, Oregon 97396

Compiled 1-3-75

Printed in U. S. A.

# HIPMOUNT ILLUSTRATIONS

**NOTE:** To prevent damage in shipping, the batteries have been removed from your instrument and placed in a separate container within the shipping carton. See following diagram for proper installation.

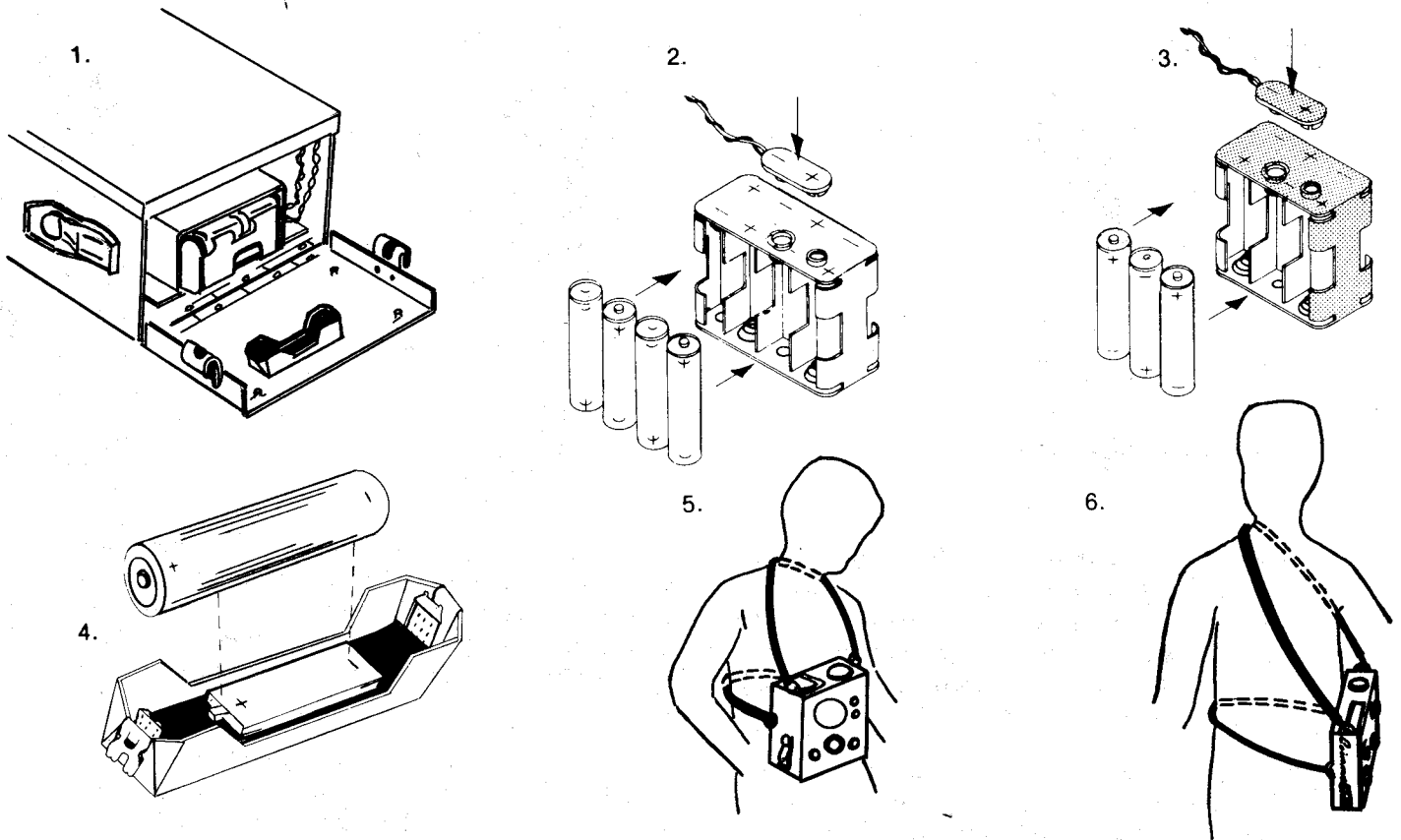

## BATTERY-PACK ILLUSTRATION

9 volt (6Pak) Black Connection  
 12 volt (8 Pak) White Connection

1.5 Volt "AA" [Battery Pack Models].....

EVEREADY  
1015

BURGESS  
910

RAY-O-VAC  
#15

When ordering replacement batteries from the factory, please state the instrument model, voltage of batteries and battery number.

## PROBE ASSEMBLY, DRAWINGS

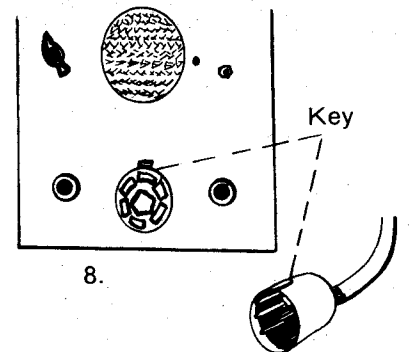
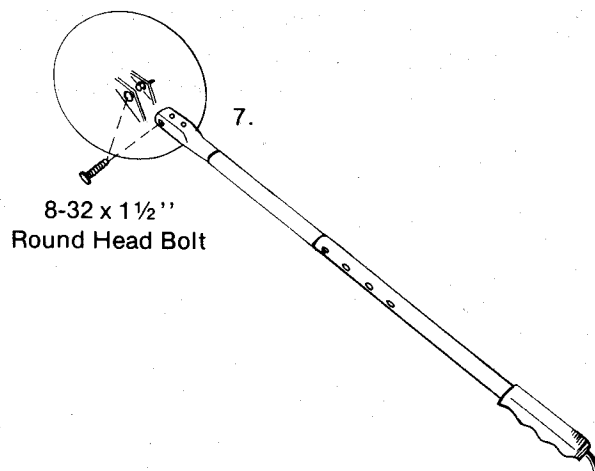



# OPERATING ILLUSTRATIONS

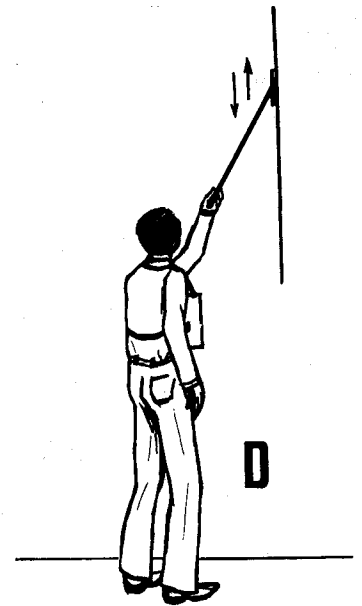
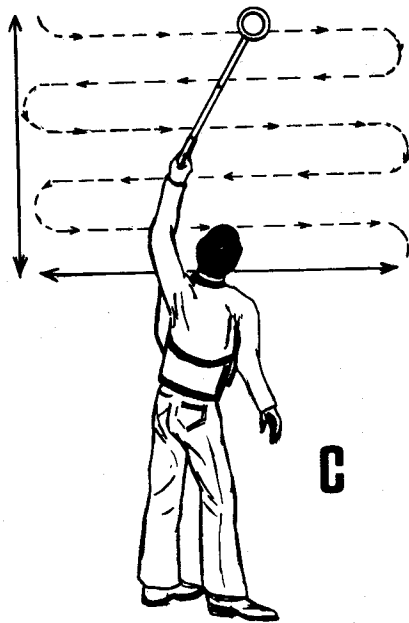
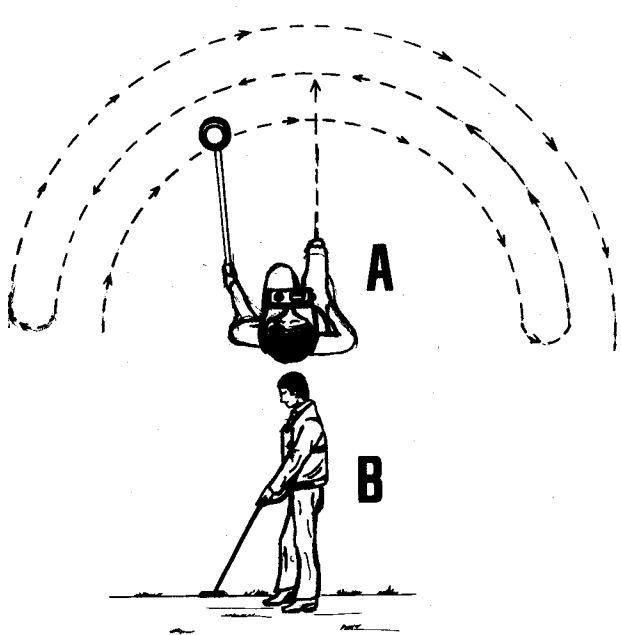

As shown in Diagrams A and B, when you are working on the ground, move forward in a straight line, at the same time, moving the loop from side to side across in front of you. The distance between each swath of the loop is determined by the size of the loop you are using. With a 6" loop you would make a 3" step, with 12" loop you would make a 6" step, and so on. Using this method of hunting enables the hunter to cover more ground, more completely, in less time. For tuning your loop, hold it as close to the ground as possible.

Diagrams C and D show you just one more of the many ways the versatile design of the White's instrument can help you either in prospecting or treasure hunting. This diagram demonstrates the extra ability the design gives in reaching to the out-of-the-way places. This system can be used for checking outcroppings, walls, etc.

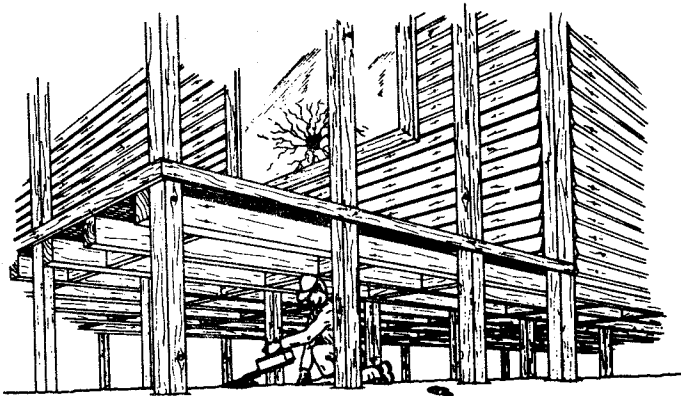

Remember, a lot of old artifacts and treasure have been found under old buildings, as well as in the attics. When going through an old homestead, never overlook any place or area that could represent a good hiding place. So if you are planning such a trip, follow these simple illustrations and prepare your instrument. At a time like this you don't want to pass up any chances.



1011 Pleasant Valley Rd.  
Sweet Home, Or. 97386